



KERN & Sohn GmbH

Ziegelei 1
72336 Balingen-Frommern
Germany

www.kern-sohn.com

+0049-[0]7433-9933-0
+0049-[0]7433-9933-149
info@kern-sohn.com

User manual Table scales

KERN FCD

Type TFCD-A

Version 1.1

2024-03

GB



TFCD_A-BA-e-2411



KERN FCD

Rev. 1.1 2024-03

User manual

Table scales

Contents

| | | |
|-------|--|----|
| 1 | Technical specification | 4 |
| 2 | Declaration of Conformity..... | 6 |
| 3 | Device overview | 7 |
| 3.1 | Parts | 7 |
| 3.2 | Keyboard | 8 |
| 3.2.1 | Introducing the numerical value | 9 |
| 3.3 | Display..... | 9 |
| 4 | Basic Information (General) | 10 |
| 4.1 | Proper use | 10 |
| 4.2 | Improper Use..... | 10 |
| 4.3 | Warranty..... | 10 |
| 4.4 | Testing equipment supervision | 11 |
| 5 | Basic safety instructions..... | 11 |
| 5.1 | Compliance with the instructions included in the user manual | 11 |
| 5.2 | Personnel training..... | 11 |
| 6 | Transport and storage..... | 11 |
| 6.1 | Checking during reception | 11 |
| 6.2 | Packaging / return transport | 11 |
| 7 | Unpacking, Installation and Commissioning..... | 12 |
| 7.1 | Installation Site, Location of Use | 12 |
| 7.2 | Unpacking and check | 12 |
| 7.3 | Integration, setting and leveling | 13 |
| 7.4 | Power supply | 13 |
| 7.5 | Rechargeable battery operation | 14 |
| 7.5.1 | Battery charging..... | 15 |
| 7.6 | Connecting peripherals..... | 15 |
| 7.7 | First start | 15 |
| 7.8 | Adjustment | 16 |

| | | |
|-------|--|----|
| 8 | Operation | 17 |
| 8.1 | Switching on/off | 17 |
| 8.2 | Zeroing | 17 |
| 8.3 | Ordinary weighing..... | 17 |
| 8.4 | Weighing with tare..... | 18 |
| 8.5 | Weight unit switching..... | 19 |
| 8.6 | Percentage weighing..... | 20 |
| 8.7 | Counting the number of pieces..... | 21 |
| 8.8 | Test weighing | 22 |
| 8.8.1 | Test weighing..... | 22 |
| 8.8.2 | Check counting | 24 |
| 8.9 | Summing | 25 |
| 9 | Setup menu..... | 26 |
| 10 | RS-232 interface..... | 27 |
| 10.1 | Technical specification | 27 |
| 10.2 | Printer mode / protocol templates (KERN YKB-01N) | 28 |
| 10.3 | Printout protocol (continuous data transmission) | 28 |
| 11 | Maintenance, service and disposal..... | 29 |
| 11.1 | Cleaning | 29 |
| 11.2 | Maintenance and service | 29 |
| 11.3 | Disposal | 29 |
| 12 | Error messages | 29 |
| 13 | Help for any minor failures..... | 30 |

1 Technical specification

| KERN | FCD 3K-3 | FCD 6K-3 |
|---|--|-----------------|
| Product number / type | TFCD 3K-3-A | TFDE 6K-3-A |
| Interval (<i>d</i>) | 0,1 g | 0,2 g |
| Weighing range (<i>Max</i>) | 3000 g | 6000 g |
| Reproducibility | 2 g | 2 g |
| Linearity | ±3 g | ±4 g |
| Minimum piece weight when counting the number of pieces in laboratory conditions* | 0.05 g | 0.1 g |
| Minimum piece weight when counting the number of pieces in standard conditions** | 0.52 g | 1 g |
| Adjustment points | 1/2/3 kg | 2/4/6 kg |
| Recommended adjustment weight (not delivered) | 3 kg (M2) | 6 kg (M2) |
| Settling time (standard) | 3 s | |
| Heating time | 10 min | |
| Weight units | g, kg, lb, oz | |
| Air humidity | max. 80%, relative (non-condensing) | |
| Permissible ambient temperature | 0°C to +40°C | |
| Input voltage of the device | 5 V, 1 A | |
| Input voltage of the power supply | 100–240 VAC; 50/60 Hz | |
| Battery (optional) | 3.7 V / 4 Ah | |
| Rechargeable battery operation | operating time 80 h (illumination off) operating time 50 h (illumination on) charging time ca. 5 h | |
| housing dimensions [mm] | 320 × 340 × 110 (width × depth × height) | |
| Scale plate, stainless steel [mm] | 300 × 230 × 18 | 300 × 230 × 18 |
| Net weight [kg] | 2.9 | |
| Interface | RS-232 | |

| KERN | FCD 10K-3 | FCD 30K-2 |
|---|--|------------------|
| Product number / type | TFCD 10K-3-A | TFCD 30K-2-A |
| Interval (<i>d</i>) | 0,5 g | 1 g |
| Weighing range (<i>Max</i>) | 15,000 g | 30,000 g |
| Reproducibility | 10 g | 10 g |
| Linearity | ±15 g | ±30 g |
| Minimum piece weight when counting the number of pieces in laboratory conditions* | 0.2 g | 0.5 g |
| Minimum piece weight when counting the number of pieces in standard conditions** | 2 g | 5 g |
| Adjustment points | 5/10/15 kg | 10/20/30 kg |
| Recommended adjustment weight (not delivered) | 15 kg (M2) | 30 kg (M2) |
| Settling time (standard) | 3 s | |
| Heating time | 10 min | |
| Weight units | g, kg, lb, oz | |
| Air humidity | max. 80%, relative (non-condensing) | |
| Permissible ambient temperature | 0°C to +40°C | |
| Input voltage of the device | 5 V, 1 A | |
| Input voltage of the power supply | 100–240 VAC; 50/60 Hz | |
| Battery (optional) | 3.7 V / 4 Ah | |
| Rechargeable battery operation | operating time 80 h (illumination off) operating time 50 h (illumination on) charging time ca. 5 h | |
| housing dimensions [mm] | 320 × 340 × 110 (width × depth × height) | |
| Scale plate, stainless steel [mm] | 300 × 230 × 18 | |
| Net weight [kg] | 2.9 | |
| Interface | RS-232 | |

*** Minimum piece weight when counting the number of pieces in laboratory conditions:**

- There are optimum ambient conditions to count pieces with high resolution
- No diversification of the counted pieces' weight

****Minimum piece weight when counting the number of pieces in standard conditions:**

- There are unsteady ambient conditions (wind gusts, vibrations)
- There is diversification of the counted pieces' weight

Dimensions:

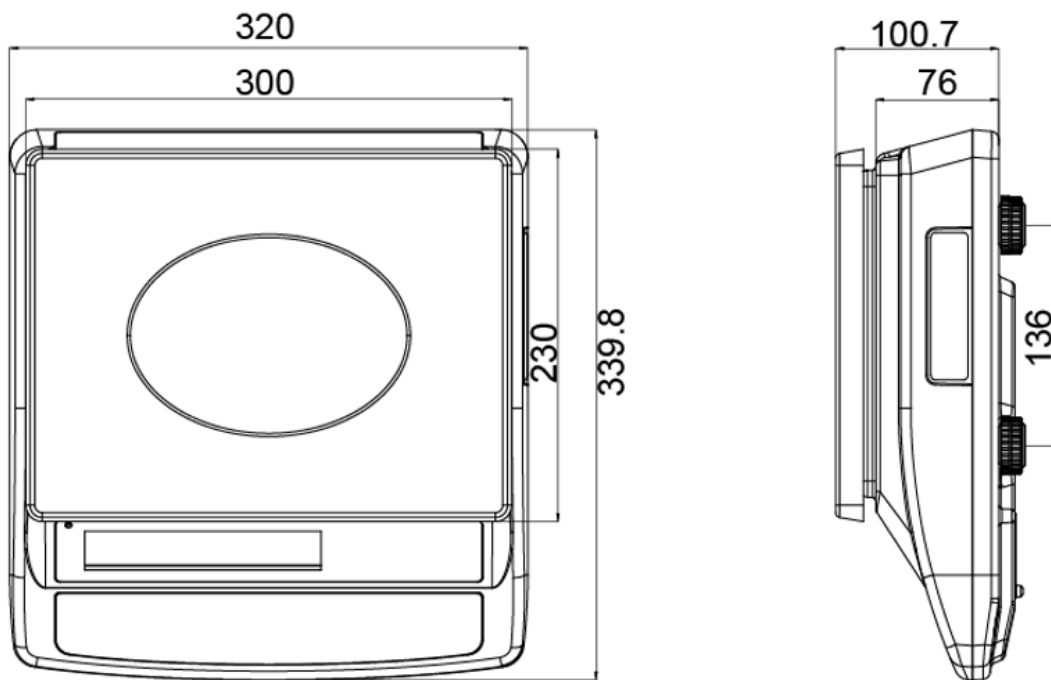

2 Declaration of Conformity

The valid Declaration of Conformity EC/UE is available at:

www.kern-sohn.com/ce

3 Device overview

3.1 Parts



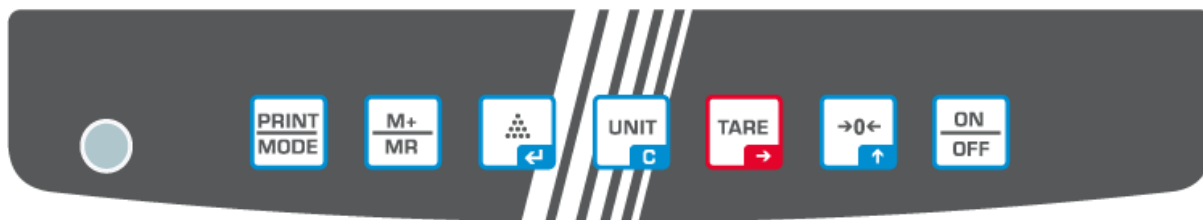

| Item | Name |
|------|--------------------------|
| 1 | Scale plate |
| 2 | Display |
| 3 | Keyboard |
| 4 | RS-232 interface |
| 5 | Battery charge indicator |
| 6 | Leveler |
| 7 | Leveling screw foot |
| 8 | Power supply socket |

3.2 Keyboard





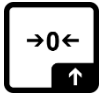

| Button | Name | Function in the operating mode | Menu function |
|--------|---------------|--|--|
| | PRINT button | <ul style="list-style-type: none"> ➤ Weight data transfer via the interface | <ul style="list-style-type: none"> ➤ Displaying the configuration menu (by pressing and holding the button) |
| | M Button | <ul style="list-style-type: none"> ➤ Summing ➤ Displaying the “total” value | |
| | Button | <ul style="list-style-type: none"> ➤ Entering the mean amount of a single piece | <ul style="list-style-type: none"> ➤ Selection confirmation ➤ Leaving menu / return to the weighing mode |
| | UNIT button | <ul style="list-style-type: none"> ➤ Weight unit switching ➤ Deleting the total memory | |
| | TARE button | <ul style="list-style-type: none"> ➤ Taring | <ul style="list-style-type: none"> ➤ Navigation button → |
| | ZERO button | <ul style="list-style-type: none"> ➤ Zeroing | <ul style="list-style-type: none"> ➤ Navigation button ↑ |
| | ON/OFF button | <ul style="list-style-type: none"> ➤ Switching on/off | |

3.2.1 Introducing the numerical value

| Button | Name | Function |
|---|---------------------|-----------------------------------|
|  | Navigation button → | Selection of the right-hand digit |
|  | Navigation button ↑ | Increasing the digit value (0–9) |
|  | Navigation button ← | Confirmation of the entered data |

3.3 Display

| Symbol | Description |
|---|---|
|  | Battery charging indicator |
|  | Discharged battery |
|  | Tolerance symbols for check weighing |
| ○ | Stabilization indicator |
| ZERO | Zero indicator |
| GROSS | Gross weight value indicator |
| NET | Net weight value indicator |
| TARE | Weighing data is included in the tare memory |
| Σ | Weighing data is included in the total memory |
| g | Weight unit “gram” |
| kg | Weight unit “kilogram” |
| lb | Weight unit “pound” |
| oz | Weight unit “ounce” |
|  | Negative value indicator |

4 Basic Information (General)

4.1 Proper use

The balance you purchased is intended to determine the weighing value of material to be weighed. It is intended to be used as a “non-automatic balance”, i.e. the material to be weighed is manually and carefully placed in the centre of the weighing plate. As soon as a stable weighing value is reached, the weighing value can be read.

4.2 Improper Use

- Our balances are non-automatic balances and not provided for use in dynamic weighing processes. However, the balances can also be used for dynamic weighing processes after verifying their individual operative range, and here especially the accuracy requirements of the application.
- Do not leave permanent load on the weighing plate. This may damage the measuring system.
- Impacts and overloading exceeding the stated maximum load (max) of the balance, minus a possibly existing tare load, must be strictly avoided. Balance may be damage by this.
- Never operate the balance in explosive environment. The serial version is not explosion protected.
- The structure of the balance may not be modified. This may lead to incorrect weighing results, safety-related faults and destruction of the balance.
- The balance may only be used according to the described conditions. Other areas of use must be released by KERN in writing.

4.3 Warranty

Warranty claims shall be voided in case:

- Our conditions in the operation manual are ignored
- The appliance is used beyond the described uses
- The appliance is modified or opened
- Mechanical damage or damage by media, liquids, natural wear and tear
- The appliance is improperly set up or incorrectly electrically connected
- The measuring system is overloaded

4.4 Testing equipment supervision

Within the quality assurance system, you must check the technical measurement properties of the scale and possibly of the available reference weight regularly. To that aim, the responsible user should define a relevant cycle, as well as the type and scope of such an inspection. The information on the supervision of the testing equipment, i.e. scales, and the required reference weights, can be found on the home page of KERN (www.kern-sohn.com). The reference weights and scales can be calibrated fast and for a low cost in the KERN calibration laboratory (against the national reference) approved by DKD (Deutsche Kalibrierdienst).

5 Basic safety instructions

5.1 Compliance with the instructions included in the user manual



- ⇒ Before you set and start the device, read this user manual thoroughly even if you are familiar with KERN scales.
- ⇒ All language versions contain non-binding translation. Only the original document in German is binding.

5.2 Personnel training

The device can be operated and maintained solely by trained workers.

6 Transport and storage

6.1 Checking during reception

Immediately after you have received the shipment, please check if it is free from any visible outer damage. The same applies for the unpacked device.

6.2 Packaging / return transport



- ⇒ Please keep all the parts of the original packaging in case you had to send it back to us.
- ⇒ Always use the original packaging for the return transport.
- ⇒ Before you dispatch the device, disconnect any connected cables as well as loose/moving parts.
- ⇒ Reinstall any transport locks, if present.
- ⇒ Protect all the parts, e.g. wind breaker, scale plate, power supply etc. from slipping and damage.

7 Unpacking, Installation and Commissioning

7.1 Installation Site, Location of Use

The balances are designed in a way that reliable weighing results are achieved in common conditions of use.

You will work accurately and fast, if you select the right location for your balance.

On the installation site observe the following:

- Place the balance on a firm, level surface.
- Avoid extreme heat as well as temperature fluctuation caused by installing next to a radiator or in the direct sunlight.
- Protect the balance against direct draughts due to open windows and doors.
- Avoid jarring during weighing.
- Protect the balance against high humidity, vapours and dust.
- Do not expose the device to extreme dampness for longer periods of time. Non-permitted condensation (condensation of air humidity on the appliance) may occur if a cold appliance is taken to a considerably warmer environment. In this case, acclimatize the disconnected appliance for ca. 2 hours at room temperature.
- Avoid static charge of goods to be weighed or weighing container.
- Do not operate in areas with hazard of explosive material or in potentially explosive atmospheres due to materials such as gasses, steams, mists or dusts.
- Keep away chemicals (such as liquids or gasses), which could attack and damage the balance inside or from outside.
- In the event of the occurrence of electromagnetic fields, static charges (e.g., when weighing / counting plastic parts) and unstable power supply, large display deviations (incorrect weighing results, as well as damage to the scale) are possible. Change location or remove source of interference.

7.2 Unpacking and check

Remove the device and accessories from the packaging, remove the packaging material and place the device in the target location. Check if all components included in the delivery are present and not damaged.

Scope of delivery / standard accessories:

- Scale, see chapter 3.1
- Power supply
- User manual
- Dust cover

7.3 Integration, setting and leveling

- ⇒ Remove any transport protection at the scale bottom.
- ⇒ Install the scale plates as shown in the drawing.



- ⇒ Place the scale on smooth surface.
- ⇒ Level the scale using the leveling feet. The air bubble in the leveler must be present in the marked area.

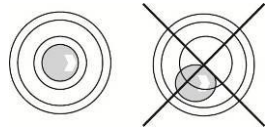

- ⇒ Check leveling at regular intervals.

7.4 Power supply



Check if the scale voltage is set correctly. The scale can be connected to the mains only when the voltage specified on the scale (sticker) and the local voltage are identical.

Always use the original power supply by KERN. Using any other products requires KERN consent.



Important information:

- Before you start the device, check the power cord for damage.
- The power cord must not have any contact with liquids.
- The plug must be always readily available.

7.5 Rechargeable battery operation

PLEASE NOTE!



- ⇒ The rechargeable battery and the charger are compatible. Always use the power supply delivered with the scale.
- ⇒ Do not use the scale when charging.
- ⇒ Always replace the battery with the one of the same type or of the type recommended by the manufacturer.
- ⇒ The battery is not protected against all the environmental impacts. Exposing the battery to specific environmental conditions may result in its fire or explosion. It may result in serious injuries or material losses.
- ⇒ Protect the battery from fire and heat.
- ⇒ Do not allow the battery to have any contact with liquids, chemicals or salts.
- ⇒ Do not expose the battery to high pressure or microwave radiation.
- ⇒ Do not modify any batteries, charger and do not tamper them.
- ⇒ Do not use any faulty, damaged or deformed battery.
- ⇒ Do not connect the electrical contacts of the battery and do not use any metal items to short circuit them.
- ⇒ The electrolyte may be released by the damaged battery. Any contact of the electrolyte with the skin or eyes may irritate them.
- ⇒ When you place or replace batteries, always pay attention to the correct polarity (see the information in the battery compartment).
- ⇒ When the power supply is connected, the battery operation mode is switched off. Always remove the battery for weighing in the power supply mode longer than 48 h! (Overheating danger).
- ⇒ If you detect any odor emitted by the battery, its heating, discoloration or deformation, disconnect it immediately from the power supply and, whenever possible, from the scale.

7.5.1 Battery charging

The rechargeable battery is charged using the supplied power cord.

Before first use, charge the battery for at least 5 hours using the power cord.

The battery symbol < > displayed on the screen means that the battery capacity will soon run down. The device may operate ca. 1 hour longer and then it will be switched off automatically. When the scale operates further without charging, a blinking <LO-BAT> symbol will be displayed.

Charge the battery using the provided power supply.

When charging, LED informs of the battery status.

red: The battery is being charged

green: The battery is fully charged

7.6 Connecting peripherals

Before you connect or disconnect any extra devices (printer, computer) to/from the data interface, the scale should always be disconnected from the mains.

Use solely accessories and peripherals supplied by KERN with the scale, being perfectly compatible with it.

7.7 First start

To get accurate weighing results using electronic scales, ensure the scales achieves the appropriate operating temperature (see “Heating time”, chapter 1). During the heating time, the scale must be connected to the power source (the socket, rechargeable battery or batteries).

The scale accuracy depends on the local standard gravity.





Always follow the guidelines in the “Adjustment” chapter.

7.8 Adjustment

As the standard gravity value is not the same in every spot on Earth, every display with the scale plate connected should be adjusted, in line with the weighing rules resulting from the laws of physics, to the standard gravity in the scale location (provided the scale system has not already been subject to factory adjustment in its location). Such an adjustment process should be carried out during the first start, following every location change and also in the case of any ambient temperature fluctuations. To ensure achieving accurate measurement data, it is also recommended to carry out regular display adjustment also in the weighing mode.

- i** • Prepare the required adjustment weight, see chapter 1.
Whenever possible, adjust using the adjustment weight with the weight similar to the maximum load of the scale (the adjustment weight is recommended, see chapter 1). The adjustment may also be carried out using weights with other nominal values or tolerance classes, but this is not optimal from the measurement technique perspective. The adjustment weight precision must correspond to the interval [d] of the scale, though preferably it should be a bit higher. For information concerning reference weights, see online at: <http://www.kern-sohn.com>
- Ensure stable environmental conditions. The heating time is required for the stabilization (see chapter 1).
- Ensure there are no objects on the scale plate.

What to do:

- ⇒ Switch the scale on and when the autotest is carried out, press and hold the  button until the $\langle \overset{2}{E} r \square \rangle$ is displayed.
- ⇒ Release the button . $\langle _ _ _ _ \rangle$ and then the blinking symbol of the first adjustment point will be displayed.
- ⇒ Using the **ZERO** button, select the required adjustment weight, see chapter 1 “Adjustment points” or “Recommended adjustment weight”.
- ⇒ Place the adjustment weight and confirm by pressing .
- ⇒ Wait until $\langle PASS \rangle$ is displayed.
- ⇒ Remove the adjustment weight.
- ⇒ Press . After the successful adjustment, the scale will switch to the weighing mode again automatically.
If there is any adjustment error or if an incorrect adjustment weight is used, the error message is displayed. Repeat the adjustment process.

8 Operation

8.1 Switching on/off

Switching on:

- ⇒ Press the **ON/OFF** button.
Once the display is lit, the scale autotest will be carried out.
Wait until the weight is displayed, the scale is ready for use.

Switching off:

- ⇒ Press the **ON/OFF** button, the display will go off.

8.2 Zeroing

Zeroing corrects the effect of small pollutants on the scale plate.

- ⇒ Remove the load from the scale.
- ⇒ Press **ZERO**, the zero indications and **<ZERO>** symbol will be displayed.

8.3 Ordinary weighing

- ⇒ Check the zero indication, whenever required zero by pressing the **ZERO** button.
- ⇒ Place the weighed material.
- ⇒ Wait until the stabilization indicator is displayed [O].
- ⇒ Read out the weighing result.



Overload warning

Always avoid any device overload higher than the stipulated maximum load (*Max*), deducting the tare from the existing load. This could damage the device.

The exceeded maximum load is indicated with **--ol--**. Reduce the scale load or reduce the initial load.

8.4 Weighing with tare

The empty weight of any container used for weighing can be tared, pressing the button which results in displaying the net weight of the weighed material during consecutive weighing processes.

- ⇒ Place the scale container on the scale plate.
- ⇒ Wait until the stabilization indicator is displayed [O], and press the **TARE** button. The container weight is saved in the scale memory. Zero, "**TARE**" and "**NET**" are displayed.
"**NET**" indicates all displayed weight values are net values.
- ⇒ Place the weighed material.
- ⇒ Wait until the stabilization indicator is displayed [O].
- ⇒ Read out the net weight.



- After the load is removed from the scale, the tare weight is displayed as a negative value.
- To delete the saved tare value, remove the load from the scale plate and press **TARE** button.
- The taring process can be repeated any number of times, e.g. when weighing several mixture ingredients (making up the weight). The limit is reached when the complete taring scope is used.

8.5 Weight unit switching

When you press **UNIT** in the weighing mode, you may switch between the indications and the enabled weight units or application units.

Activating the switchable weight units:

- ⇒ Press **UNIT** and hold it for 3 s until $\langle \text{U} - \text{On} \rangle$ is displayed.
- ⇒ Using the **TARE** button, select the required setting.
You can choose:

| | |
|----------|--------|
| kg | on/off |
| lb | on/off |
| oz | on/off |
| hj | on/off |
| tj | on/off |
| cj | on/off |
| pc [pcs] | on/off |
| pr [%] | on/off |

- ⇒ Using the **ZERO** button, enable (on) or disable (off) the selected unit.
- ⇒ Using **TARE**, select the next unit and enable/disable it by pressing **ZERO**.
The process should be repeated for every unit.
- ⇒ Confirm by pressing , the scale will switch to the weighing mode again.



Weight unit switching

- ⇒ In the weighing mode the **UNIT** button enables to switch between the enabled weight units.

i The switching function is available solely in the weighing mode.

8.6 Percentage weighing

Percentage weighing enables to display the percentage weight in reference to the reference weight.

- ⇒ Ensure the application unit [%] is enabled, see chapter 8.5.
- ⇒ Using the **UNIT** button, select the application unit [%].
<0.00%> will be displayed.
- ⇒ Place the reference weight corresponding to 100%.
- ⇒ Wait until the stabilization indicator is displayed and then confirm by pressing 
.
<5 100C> will be displayed.
- ⇒ Confirm by pressing , <100.00%> symbol will be displayed.
- ⇒ Remove the reference weight, <0.00%> will be displayed.
- ⇒ From now on, the sample weight is displayed as percentage referring to the reference weight.

8.7 Counting the number of pieces



Before it is possible to count pieces using the scale, you should determine the average weight of an individual piece (unit weight), the so-called reference value. To do it, place the specific number of pieces which the counting the number of pieces will be carried out for. The scale will determine the total weight which will be divided by the number of pieces, the so-called reference piece number. Next, based on the calculated mean weight of an individual piece, the number of pieces will be counted.

- i** • The higher number of the reference pieces, the higher the accuracy of counting the number of pieces.
- For small or highly diverse pieces, the reference value must be sufficiently high.
- For the minimum weight of the counted pieces, see the “Technical specification” table.

1. Calling the piece counting mode

- ⇒ Ensure the application unit [pcs] is enabled, see chapter 8.5.
- ⇒ Using the **UNIT** button, select the application unit [pcs].
<0^{pcs}> will be displayed.

2. Setting the reference value

- ⇒ Whenever required, place an empty container on the scale and tare it.
- ⇒ Place the required number of reference items.
- ⇒ Press , the currently set number of reference pieces will be displayed (e.g. 10)
<SP 10>.
- ⇒ Using the **ZERO** button, select the number of reference pieces (10, 20, 50, 100, 200, 500) corresponding to the placed reference load and confirm by pressing .
- ⇒ The mean weight of an individual piece will be determined by the scale and then the piece quantity <10^{pcs}> will be displayed.
- ⇒ Remove the reference load. The scale is in the counting mode and counts all pieces present on the scale plate.

3. Leaving the piece counting mode

- ⇒ Every pressing of the **UNIT** button results in switching to another weight unit (e.g. kg).

8.8 Test weighing



i The function is available starting from weight values above 20 d.

Activating the test weighing mode:

- ⇒ In the weighing mode, press **TARE**, <L 10-0F> will be displayed.
- ⇒ Pressing **TARE** enables to switch between <L 10-00> a <L 10-0F>.
 - <L 10-0F> function deactivated
 - <L 10-00> function activated

8.8.1 Test weighing

The <Test weighing> application enables to determine the upper and lower limit value and, consequently, to ensure the weight of the weighed material belongs to the range between the determined tolerance limits.



Exceeding the limit values (fall below and rise above) is signaled with a visual indication (tolerance symbols , **OK**, ) and an audible indication.

Setting conditions of sending and limits:

1. In the weighing mode, press and hold the **ZERO**, <L 10E> will be displayed.
2. Using the **ZERO** button, select the required signaling condition.
You can choose:



| | |
|------|---|
| 10E | <ol style="list-style-type: none"> 1. If the weighed portion is in the present limit range, a sound is heard and a tolerance symbol OK is displayed. 2. If the weighed portion is below the lower limit value, the sound is not heard and the tolerance symbol UNDER is displayed. 3. If the weighed portion is above the upper limit value, the sound is not heard and the tolerance symbol OVER is displayed. |
| 010E | <ol style="list-style-type: none"> 1. If the weighed portion is in the present limit range, a sound is not heard and a tolerance symbol OK is displayed. 2. If the weighed portion is below the lower limit value, the sound is heard and the tolerance symbol UNDER is displayed. 3. If the weighed portion is above the upper limit value, the sound is heard and the tolerance symbol OVER is displayed. |

| | |
|----|---|
| Hi | <ol style="list-style-type: none"> 1. If the weighed portion is above the upper limit value, the sound is heard and the tolerance symbol OVER is displayed. 2. If the weighed portion is below the upper limit value, the sound is not heard and the tolerance symbol UNDER is displayed. |
| Lo | <ol style="list-style-type: none"> 1. If the weighed portion is below the lower limit value, the sound is heard and the tolerance symbol UNDER is displayed. 2. If the weighed portion is above the lower limit value, the sound is not heard and the tolerance symbol OVER is displayed. |

3. Confirm the selection by pressing , <St Lo> will be displayed for a while. The window for value entry in the numerical form will be displayed where you can enter the lower limit value. The tolerance symbol  will be displayed, the active item is blinking.
4. Enter the lower limit value (for entering the numerical value see chapter 3.2.1) and confirm.
5. <St Hi> will be displayed for a while. The window for value entry in the numerical form will be displayed where you can enter the upper limit value. The tolerance symbol  will be displayed, the active item is blinking.
6. Enter the upper limit value (for entering the numerical value see chapter 3.2.1) and confirm.
7. <End> will be displayed for a while, the scale will switch to the weighing mode again.

Tolerance check start:



- ⇒ Ensure the test weighing mode is active. To do it, press **TARE** and hold it long enough for <L n - OF> to be displayed.
- ⇒ Place the weighed material (< 20 g) and, based on the tolerance symbols / audible signal, check if the weighed material belongs to the preset tolerance range.

| Weighed material below the preset tolerance | Weighed material in the preset tolerance range | Weighed material above the preset tolerance |
|---|---|---|
|  |  |  |









- i**
- To cancel the limit values, enter <00000.0 kg>.
 - Deactivate the test weighing mode. To do it, press **TARE** and hold it long enough for <L n - OF> to be displayed.

8.8.2 Check counting

The **<Test counting>** application enables to determine the upper and lower limit value and, consequently, to ensure that the target number of pieces belongs to the range between the determined tolerance limits.







When the target value is achieved, the sound is heard and an optical signal is visible (tolerance symbols , , ).

Setting conditions of sending and limits:

- ⇒ Using the **UNIT** button, select the application unit [pcs].
 will be displayed.
- ⇒ Press **ZERO** and hold it for 3 s,  will be displayed.
- ⇒ Using the **ZERO** button, select the required signaling condition. For selection options see chapter 8.8.1 / step 2:
- ⇒ Confirm the selection by pressing ,  will be displayed for a while. The window for value entry in the numerical form will be displayed where you can enter the lower limit value. The tolerance symbol  will be displayed, the active item is blinking.
- ⇒ Enter the lower limit value (for entering the numerical value see chapter 3.2.1) and confirm.
- ⇒  will be displayed for a while. The window for value entry in the numerical form will be displayed where you can enter the upper limit value. The tolerance symbol  will be displayed, the active item is blinking.
- ⇒ Enter the upper limit value (for entering the numerical value see chapter 3.2.1) and confirm.
- ⇒  will be displayed for a while, the scale will switch to the weighing mode again.

Tolerance check start:

- ⇒ Ensure the average weight of a single piece is determined (see chapter 8.7.)
- ⇒ Place the weighed material (< 20 d) and, based on the tolerance symbols / audible signal, check if the weighed material belongs to the preset tolerance range.

| Weighed material below the preset tolerance | Weighed material in the preset tolerance | Weighed material above the preset tolerance |
|--|--|--|
|   |   |   |



- To cancel the limit values, enter <00000>.
- Deactivate the test weighing mode. To do it, press **TARE** and hold it long enough for  to be displayed.

8.9 Summing

The function enables to add individual weighing values to the total memory by pressing the button.



The function is available starting from weight values above 20 d.

Summing the weighed material:

- ⇒ Whenever required, place an empty container on the scale and tare it.
- ⇒ Place the first weighed material. Wait until the stabilization indicator [O] is displayed and then press **M**. The weight value will be saved. The Σ symbol will be displayed.
- ⇒ Remove the weighed material. The subsequent weighed material can be added only when the indication \leq zero.
- ⇒ Place the second weighed material. Wait until the stabilization indicator [O] is displayed and then press **M**. The weight value will be added to the total memory. The total will be displayed alternately with the currently placed weight for ca. 5 s.
- ⇒ Whenever required, add the subsequent weighed material as described above. Load should be removed from the scale between consecutive weighing procedures.
- ⇒ This process may be repeated 99 times until you reach the scale weighing range.

Displaying the “total” value:

- ⇒ When zero is displayed, press **M**. The total weight will be displayed for ca. 5 s.

Deleting the total memory:

- ⇒ When zero is displayed, press the **M** button. When the total weight is displayed, press **UNIT**.

9 Setup menu

The setup menu enables to adapt the scale settings / scale behavior to your requirements (e.g. ambient conditions, special weighing processes).

Menu navigation:

| | |
|--|---|
| Displaying the menu | ⇒ In the weighing mode, press and hold the PRINT for 3 s. |
| Selecting the menu item | ⇒ Individual menu items can be selected consecutively, pressing TARE . |
| Setting selection | ⇒ Confirm the selection of the menu item by pressing the ZERO button. The current setting will be displayed. |
| Changing settings | ⇒ The TARE button enables to switch between the available settings. |
| Setting confirmation / Menu leaving | ⇒ Press  , the scale will switch to the weighing mode again. |

Overview:

| Main menu block | Submenu item | Available settings / explanation |
|--|---------------------|---|
| BuAd96 Transmission speed | BuAd96* | Transmission speed 9600 |
| | BuAd48 | Transmission speed 4800 |
| RS CO Data transmission | rS oFF | Data transmission off |
| | rS Co | Continuous data transmission of stable/unstable weighing values |
| | rS SCo* | Continuous data transmission of stable weighing values |
| | rS St | Data transmission for an unstable weighing value |
| | rS Co | Data transmission after PRINT is pressed |
| bl-AY Display backlight | bl-AY* | The backlight is switched on automatically when load is changed or when the device is operated |
| | bl-on | Display backlight always on |
| | bl-oFF | Display backlight always off |
| FiLt-1 Filter | FiLt-1* ~ FiLt-5 | Adaptation to the ambient conditions, you can select from FiLt-1 ~ FiLt-5. The higher the filter degree, the faster the response time/but also the higher the sensitivity. |

| | | |
|---|---------------------|---|
| Zero-1 Maintaining zero | ZEro0* ~ ZEro9 | Automatic zero maintenance, possible to choose from 0 <i>d</i> to 9 <i>d</i> |
| | | <p>i</p> <p>If the amount of the weighed material is reduced or increased significantly, the scale's "stabilizing and compensating" mechanism can result in displaying erroneous weighing results! (e.g.: slow outflow of the liquid from the container placed on the scale, evaporating processes).</p> <p>When dosing with small weight fluctuations, it is recommended to switch this function off.</p> |
| L-AZ-0 Setting a decimal point | L-AZ 0* ~ L-AZ 9 | The load scope where the scale returns to zero, you can choose from 0 <i>d</i> to 9 <i>d</i> |

Factory settings are indicated by "*".

10 RS-232 interface

RS-232 ensures two-way data exchange between the scale and external devices. Data is sent asynchronously in ASCII code.

To ensure communication between the balance and the printer, the following conditions must be met:

- Connect the scale with the printer interface using the appropriate cable. Trouble-free operation is ensured only when the appropriate interface cable by KERN is used.
- Communication parameters (e.g. transmission speed) of the scale and the printer must be compliant.

10.1 Technical specification

Port

9-Pin--pin mini D-Sub plug

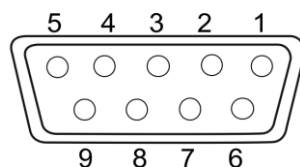

Pin 2 RXD

Input

Pin 3 TXD

Output

Pin 5 GND

Signal ground

Transmission
speed

The choice of 4800/9600

10.2 Printer mode / protocol templates (KERN YKB-01N)

| | |
|-------------------------------|--|
| Weighing: | + 1.0745 kg |
| | + 0.8735 kg |
| Counting the number of pieces | + 200PC |
| Percentage weighing | + 100.00% |
| Summing | No possibility to connect with the printer |

10.3 Printout protocol (continuous data transmission)

| Byte | 1 | 2 | 3 | 4 | 5 | 6 | 7 | 8 | 9 | 10 | 11 | 12 | 13 |
|------|---|------|------|------|------|---|---|---|---|----|------|------|----|
| | + | <20> | <20> | 1 | 0 | 7 | 4 | . | 5 | g | <CR> | <LF> | |
| | - | <20> | <20> | <20> | <20> | 5 | 0 | . | 6 | g | <CR> | <LF> | |
| O | L | | | | | | | | | | | | |

| Nr | Description |
|---------|--|
| 1 | The sign (plus/minus); alphabet: O |
| 2 ~ 8 | 7 bits of weighing value including the decimal point |
| 9 ~ 10 | Weight unit |
| 11 ~ 12 | End symbol |
| <20> | Space |

11 Maintenance, service and disposal



Before you start any works related to the maintenance, cleaning and repair, disconnect the device from the operating voltage.

11.1 Cleaning

Do not use any aggressive cleaning agents (solvents etc.), but clean the device with a cloth and mild soap solution. The liquid must not get inside the device. Wipe with a dry, soft cloth.

Any loose specimen/powder remains can be removed carefully with a brush or a handheld vacuum cleaner.

Remove any scattered weighed material immediately.

11.2 Maintenance and service

- ⇒ The device can be operated and maintained solely by the technicians trained and authorized by KERN.
- ⇒ Disconnect from the mains before opening.

11.3 Disposal

The packaging and the device should be disposed in accordance with the national or regional law in the location where the device is operated.

12 Error messages

| Error message | Explanation |
|---------------|--|
| --ol-- | Overloading |
| B-ERR | Discharged batteries/rechargeable batteries |
| Err 9 | Summing error |
| P-ERR | Average weight of a single piece outside the range |

13 Help for any minor failures

If there are any program execution problems, the scale should be switched off and disconnected from the mains for a while. Next, the weighing process should be started anew.

| Problem | Possible cause |
|--|---|
| The weight indicator is not lit. | <ul style="list-style-type: none">• The scale is not on.• Interrupted mains connection (mains cable not connected/damaged).• Mains voltage failure. |
| The weight indication keeps fluctuating. | <ul style="list-style-type: none">• Draft / air movements.• Table/air vibrations.• The scale plate is in contact with foreign bodies.• Electromagnetic fields / static discharge (select another location / if possible, switch off the interfering device). |
| The weighing result is clearly wrong. | <ul style="list-style-type: none">• The scale indication was not reset.• Incorrect adjustment.• Scale not placed on a level surface.• There are heavy temperature fluctuations.• The heating time not observed.• Electromagnetic fields / static discharge (select another location / if possible, switch off the interfering device). |