

Balance Kit SAUTER CW RB · CW KFNB

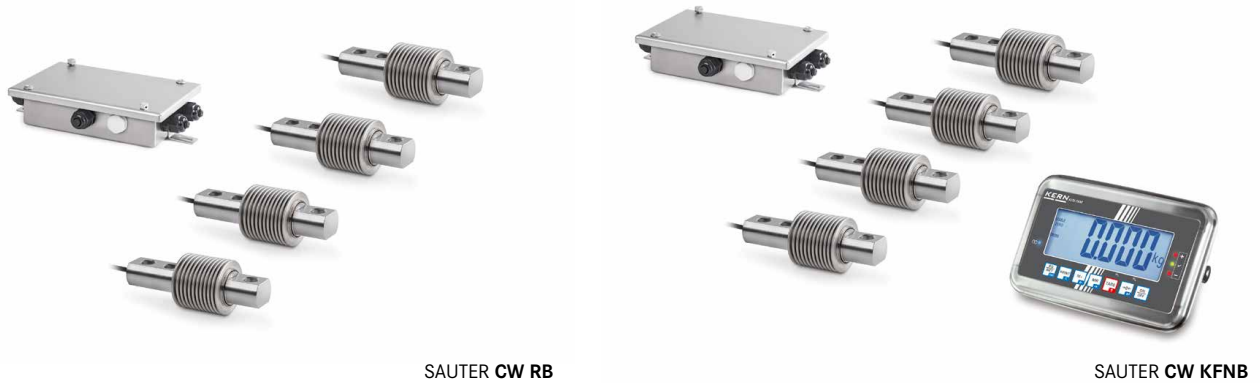

Balance kit for individual assembly of floor scales – suitable for use in harsh industrial environments with humid environmental conditions

Features

- With SAUTER scale kits, individual weighing solutions can be put together, for example, individual balance manufacturing in agriculture or the food industry. In this way, a wide range requirements in terms of dimensions, materials, combinations of peripheral devices etc. can be fulfilled. Especially suitable for the manufacture of platform scales, weigh hoppers, silo scales, weighing devices for manure spreaders in agriculture, weighing device in municipal vehicles, e.g. waste disposal or winter road services, flush-mounted floor scales and other weighing devices

- Details for weighing cells:
 - CE and RoHS compliant
 - **1** Protection against dust and water splashes IP68/IP69K
 - Stainless steel
 - 2-wire connection
 - Nominal sensitivity: 3 mV/V
- Junction box SAUTER CJ X467:
 - **2** Robust housing made of stainless steel with IP67 dust and spray protection
- Note: Use the SAUTER CW RB in combination with one of our display devices, for example, KFS-TM, YKV, CE HS

Accessories

- Assembly of components, 50 kg - 350 kg, KERN 965-412
- Assembly of components, 350 kg - 1500 kg, KERN 965-413

Note: Some weighing processes require an individual special solution. For this reason we have special scale kits available for you which you can use to create a tailor-made solution which is just right for you. In this way you can use the most varied platform sizes or individual weighing systems, e.g. within larger production plants, which match your requirements perfectly.

STANDARD

2	1	1		

Model	Nominal load	Scope of delivery Load cells	Scope of delivery
SAUTER	kg		
CW 300R	300	4 × CB 100-3Q1	- 1 Junction box CJ X467
CW 600R	600	4 × CB 200-3Q1	
CW 300RKFN	300	4 × CB 100-3Q1	- 1 Display device KFN-TM
CW 600RKFN	600	4 × CB 200-3Q1	- 1 Junction box CJ X467

 <p>Adjusting program (CAL) For quick setting of the instrument's accuracy. External adjusting weight required</p>	 <p>Bluetooth* data interface To transfer data from the balance/measuring instrument to a printer, PC or other peripherals</p>	 <p>Measuring units Weighing units can be switched to e.g. non-metric. Please refer to website for more details</p>	 <p>Conformity assessment Models with type approval for construction of verifiable systems</p>
 <p>Calibration block Standard for adjusting or correcting the measuring device</p>	 <p>WIFI data interface To transfer data from the balance/measuring instrument to a printer, PC or other peripherals</p>	 <p>Measuring with tolerance range (limit-setting function) Upper and lower limiting can be programmed individually. The process is supported by an audible or visual signal, see the relevant model</p>	 <p>DAkkS calibration possible The time required for DAkkS calibration is shown in days in the pictogram</p>
 <p>Peak hold function Capturing a peak value within a measuring process</p>	 <p>Data interface infrared To transfer data from the measuring instrument to a printer, PC or other peripheral devices</p>	 <p>Protection against dust and water splashes IPxx The type of protection is shown in the pictogram cf. DIN EN 60529:2000-09, IEC 60529:1989 +A1:1999+A2:2013</p>	 <p>Factory calibration (ISO) The time required for factory calibration is specified in the pictogram</p>
 <p>Scan mode Continuous capture and display of measurements</p>	 <p>Control outputs (optocoupler, digital I/O) To connect relays, signal lamps, valves, etc.</p>	 <p>ZERO Resets the display to "0"</p>	 <p>Package shipment The time required for internal shipping preparations is shown in days in the pictogram</p>
 <p>Push and Pull The measuring device can capture tension and compression forces</p>	 <p>Analogue interface To connect a suitable peripheral device for analogue processing of the measurements</p>	 <p>Battery operation Ready for battery operation. The battery type is specified for each device</p>	 <p>Pallet shipment The time required for internal shipping preparations is shown in days in the pictogram</p>
 <p>Length measurement Captures the geometric dimensions of a test object or the movement during a test process</p>	 <p>Analogue output For output of an electrical signal depending on the load (e.g. voltage 0 V - 10 V or current 4 mA - 20 mA)</p>	 <p>Rechargeable battery pack Rechargeable set</p>	
 <p>Focus function Increases the measuring accuracy of a device within a defined measuring range</p>	 <p>Statistics Using the saved values, the device calculates statistical data, such as average value, standard deviation etc.</p>	 <p>Plug-in power supply 230V/50Hz in standard version for EU. On request GB, AUS or US version available</p>	
 <p>Internal memory To save measurements in the device memory</p>	 <p>PC Software To transfer the measurement data from the device to a PC</p>	 <p>Integrated power supply unit Integrated, 230V/50Hz in EU. More standards e.g. GB, AUS or US on request</p>	
 <p>Data interface RS-232 Bidirectional, for connection of printer and PC</p>	 <p>Printer A printer can be connected to the device to print out the measurement data</p>	 <p>Motorised drive The mechanical movement is carried out by an electric motor</p>	
 <p>Profibus For transmitting data, e.g. between scales, measuring cells, controllers and peripheral devices over long distances. Suitable for safe, fast, fault-tolerant data transmission. Less susceptible to magnetic interference</p>	 <p>Network interface For connecting the scale/measuring instrument to an Ethernet network</p>	 <p>Motorised drive The mechanical movement is carried out by a synchronous motor (stepper)</p>	
 <p>Profinet Enables efficient data exchange between decentralised peripheral devices (balances, measuring cells, measuring instruments etc.) and a control unit (controller). Especially advantageous when exchanging complex measured values, device, diagnostic and process information. Savings potential through shorter commissioning times and device integration possible</p>	 <p>KERN Communication Protocol (KCP) It is a standardized interface command set for KERN balances and other instruments, which allows retrieving and controlling all relevant parameters and functions of the device. KERN devices featuring KCP are thus easily integrated with computers, industrial controllers and other digital systems</p>	 <p>Fast-Move The total length of travel can be covered by a single lever movement</p>	
 <p>Data interface USB To connect the measuring instrument to a printer, PC or other peripheral devices</p>	 <p>GLP/ISO record keeping of measurement data with date, time and serial number. Only with SAUTER printers</p>		

*The Bluetooth® word mark and logos are registered trademarks owned by Bluetooth SIG, Inc. and any use of such marks by KERN & SOHN GmbH is under license. Other trademarks and trade names are those of their respective owners.